



series 1704

BOOM TRUCKS

features

- 17 Ton (15,5 mton) Capacity
- 3-Section Proportional Boom 70' (21,3 m)
- Fixed Jib Option 24' (7,2 m)
- 2-Section Telescopic Jib Option 40' (12,2 m)
- Self-Lubricating Boom Slider Pads
- 121' 3" (36,9 m) Maximum Tip Height
- 2-Speed Planetary Hoist with Grooved Drum and Negative Draft Flange
- Radio ATB
- Removable Boom Rest
- Load Moment Indicator with Digital Display, CANbus Interface, Overload Shutdown and Internal Boom Length Cable
- 20' 10" (6,4 m) A-Frame Outriggers
- 10' (3 m) A-Frame Rear Stabilizers
- Optional Front Bumper Stabilizer for 360° Area of Operation; equipped with FirstUp auto retract feature.
- System Pressure Gauge
- Clamp-On Mounting
- Rugged, Weatherproof, Connectorized Electrical System. Circuit Status LED for LMI Option
- Manitex UPTIME Comprehensive Support



product guide

series 1704

GENERAL SPECIFICATIONS

BOOM

Inverted T-cross section, 3-section telescoping type, extended and retracted proportionally by a double-acting hydraulic cylinder and cable-crowd system. Fitted with easily replaceable self-lubricated wear pads for smooth operation.

Model 1770C 3-Section 27' 3-1/2" (8,3 m) retracted to 70' 0" (21,3 m) extended

Boom Point – Three non-metallic sheaves mounted on bronze bushings; removable pin-type rope guards.

Boom Elevation – Double-acting hydraulic cylinder. Working range from 10° below horizontal to 81° above.

Load Hook – 5-ton (4,5 mton) capacity hook with heavy-duty swivel and weight is provided for single-line operation.

HOIST

Maximum theoretical line speed 300 fpm (91 mpm). Maximum theoretical bottom-layer line pull 11,500 lb (5 216 kg). Two-speed planetary reducer with wet multi-disc spring applied, pressure-released internal brake and grooved drum; negative draft angle on drum flange to minimize line stacking while spooling.

Wire Rope – 300' (91,4 m) of 9/16" (14,3 mm) diameter 6 x 19 EIPS IWRC.

SWING SYSTEM

Externally mounted, double-reduction planetary gearbox driven by hydraulic motor. Maximum swing speed 1.5 rpm. Wet multi-disc brake is spring-applied, pressure released. Ball-bearing swing circle with external gear. 372° non-continuous rotation is standard.

OUTRIGGERS

A-frame link type, operated independently for precise leveling. Equipped with double-acting hydraulic cylinders. 11-1/2" (292 mm) x 17-5/8" (448 mm) pivoting pads. Bubble level located near outrigger controls.

STABILIZERS

Rear Stabilizers - A-frame rigid design, clamp mounted under truck chassis by threaded rods and cross tube. Double-acting hydraulic cylinders operated independently for precise leveling. Fixed pad size 11-1/2" (292 mm) x 12-3/4" (324 mm) with flared leading edge.

Single Front Stabilizer (Option) – Mounted to truck frame at the front for 360° crane lifting operations. May require a full strength extended chassis depending on application, consult factory. Double acting hydraulic cylinder is equipped with an in-line relief valve to ensure proper float loading. Hydraulic circuit is operated from either operator station. First-up feature automatically retracts the front stabilizer when the outriggers or stabilizers are retracted for traveling.

MOUNTING

Pedestal and subframe are mounted to chassis by threaded rods and clamp plates. No welding, drilling or bolting to truck chassis is required.

Subframe – Torsion resistant, rigid 4-plate design mounted under crane full length of truck frame.

Rear Underride Protection – Supplied on factory mounted cranes. Fabricated structure mounted at rear of carrier. Complies with Bureau of Motor Carrier Safety Standard 393.86.

Boom Rest – Heavy-duty fabrication. Easily removed to simplify loading and unloading truck deck.

CONTROL SYSTEM

Dual operator stations are equipped with four single-lever crane controls arranged in accordance with ANSI B30.5 standards. Fully proportional control valves. A system pressure gauge is mounted on the driver's side console. Each station includes individual control levers for each outrigger and stabilizer for precise leveling. These control levers are shorter and positioned towards the center of the crane away from the main crane controls for added safety. Both controls stations are equipped with engine start/stop, foot throttle, signal horn, boom angle indicator, load chart and range diagram.

HYDRAULICS

A 3-section pump direct-mounted to power take-off on truck transmission provides 32.4 gpm (123 lpm) to the hoist, 10 gpm (38 lpm) to the swing circuit and 20.6 gpm (78 lpm) to the remaining crane functions. A 70-gallon (265 liter) baffled hydraulic reservoir with strainer includes a 25-micron filter in the return line. Ball-type shutoff valve and strainer are provided in suction line. Use of SAE O-ring and face seal O-ring hydraulic fittings throughout system practically eliminates oil leaks.

Hydraulic Cylinders – All load-holding cylinders are equipped with integral holding valves.

WARNING SYSTEMS

Load Moment Indicator (LMI) – CANbus system maximize expansion capabilities. Sensors monitor boom hoist cylinder pressure, boom length and boom angle. Audio-visual indicators warn of impending overload conditions; overload shutoff feature prevents a continuous overload condition. Operator can monitor load conditions via display at the operator station, display mounting provided on both sides of the pedestal for easy access. Internal boom length sensing cable feature protects it from inadvertent damage in the field.

Radio Anti-Two-Block System – Audible warning and shutoff functions prevent hook from contacting boom point.

Back-Up Alarm – Electronic audible motion alarm activated when truck transmission is in reverse gear.

GENERAL

Electrical – State-of-the-art, weather-resistant components throughout. Environmentally sealed enclosure contains accessory circuit, terminal strips and relays. System is protected by a supplied in-line fuse. System is designed to withstand high pressure washing and varying climates.

Design/Welding – Design conforms to ANSI B30.5. Welding conforms to AWS D1.1. Tested to SAE 1063 and SAE 765.

Manuals – Operator/maintenance and parts manuals depict correct crane operation, maintenance procedures and parts listing.

Warranty – 12-month warranty covers parts and labor resulting from defects in material and workmanship.

* In order to ensure continuous improvement, specifications may change without notice.

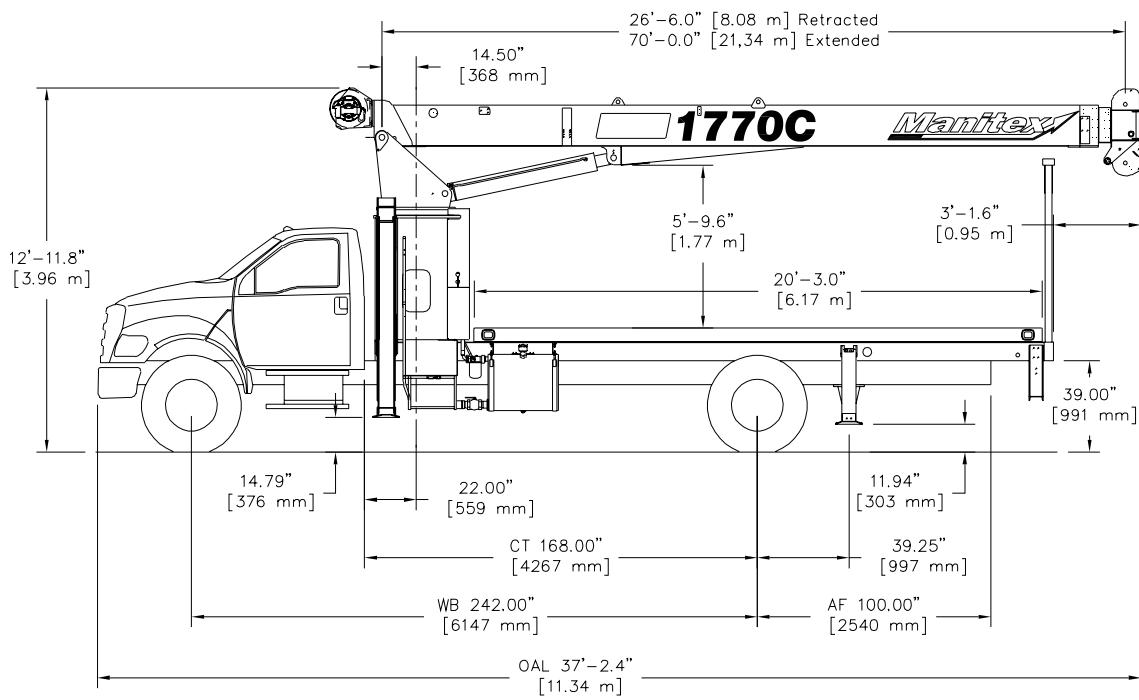

CHASSIS DATA	1770C
Wheelbase (WB)	242" 6 147 mm
Cab to Axle (CA)	168" 4 267 mm
After Frame (AF)	90" 2 286 mm
Frame Section Modulus for 180°/360° rotation (minimum)	15.9 in ³ 110,000 psi 758 422 kPa
Front Axle Gross Weight Rating	12,000 lb 5 443 kg
Rear Axle Gross Weight Rating	21,000 lb 9 525 kg
Minimum Truck Axle Weight - Front*	6,000 lb 2 721 kg
Minimum Truck Axle Weight - Back*	4000 lb 1 814 kg
Nominal Frame Width	34"-35" 864 -889 mm
*Minimum chassis weight is required to meet 85% stability requirements. Chassis data is general - not for engineering. Some dimensions depend on truck selection.	

MAX TIP HEIGHT	1770C
Configuration	Boom 70' 0" 21,3m
Retracted Boom	37' 8" 11,5m
Extended Boom	80' 8" 24,6m
Fixed or Retracted Jib	104' 6" 31,8m
Extended Jib	121' 3" 37 m

WEIGHTS	1770C
Total Crane * Less Jib	14,625 lb 6 634 kg
Fixed Jib 23.6' (7,19 m)	532 lb 241 kg
Telescopic Jib 23.6' (7,19 m) - 40.6' (12,37 m)	823 lb 373 kg
Flatbed 20' (6,10 m)	1,907 lb 865 kg
* Flatbed weight not included in crane weight	

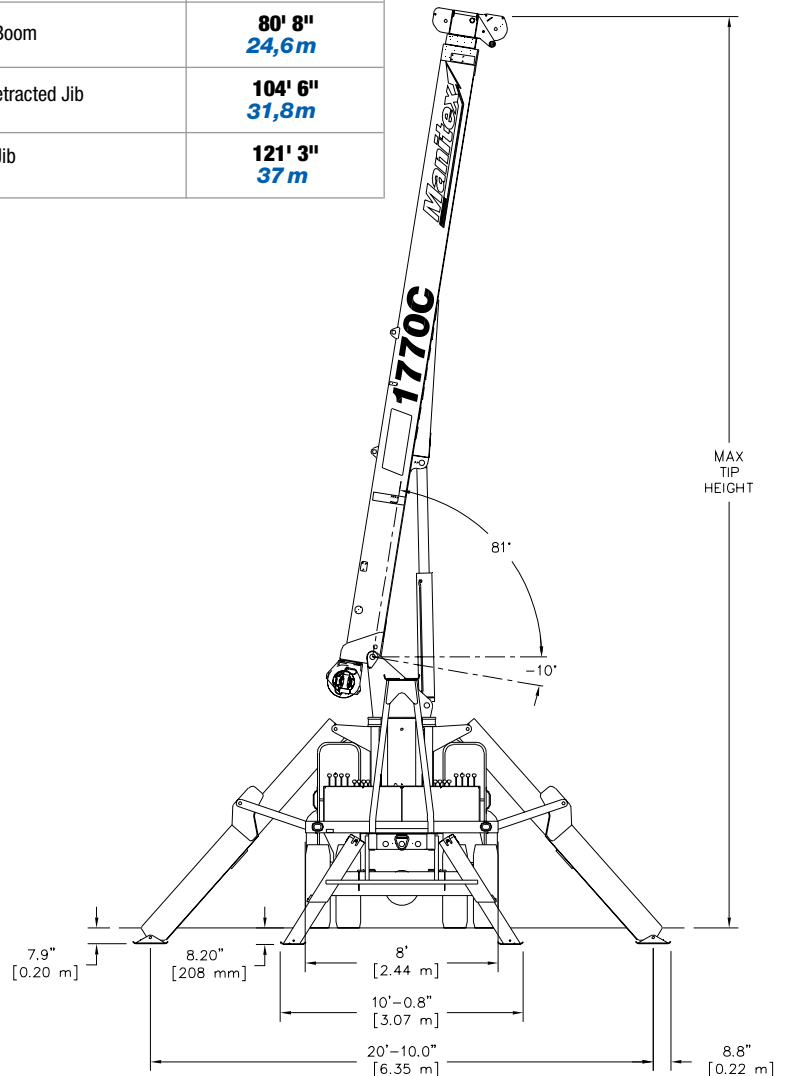

RANGE DIAGRAM

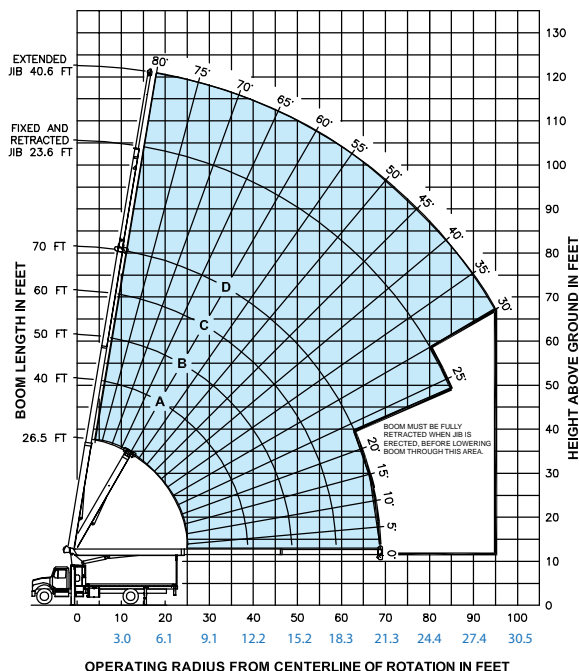

FULLY EXTENDED OUTRIGGER SPREAD: MODEL 1770C											RATINGS BY BOOM ANGLE ONLY															
MAIN BOOM LOAD RATINGS											JIB LOAD RATINGS															
Operating Radius	Boom Length		A			B			C			D			Fixed Jib			Retracted Jib			Extended Jib					
	Feet	Meters	26.5 Feet 8.08 Meters			40 Feet 12.19 Meters			50 Feet 15.24 Meters			60 Feet 18.29 Meters			70 Feet 21.34 Meters			23.6 Feet 7.19 Meters			23.6 Feet 7.19 Meters			40.6 Feet 12.37 Meters		
		°	lb	kg	°	lb	kg	°	lb	kg	°	lb	kg	°	lb	kg	°	lb	kg	°	lb	kg	°	lb	kg	
5	1.52	79	34000	15422																						
8	2.44	73	23930	10854	79	22330	10129																			
10	3.05	68	20230	9176	76	18670	8469	80	18000	8165																
12	3.66	63	17600	7983	73	16100	7303	77	15450	7008	80	13420	6087													
15	4.57	55	14420	6541	69	13400	6078	74	12780	5797	77	11900	5398	80	9400	4264										
20	6.10	40	10350	4695	61	10540	4781	68	9970	4522	72	9550	4332	76	8180	3710	80	4400	1996	80	4200	1905				
25	7.62	12	7830	3552	52	8070	3660	61	8130	3688	67	7800	3538	71	7000	3175	78	4200	1905	78	4000	1814	80	3000	1361	
30	9.14				41	6400	2903	54	6470	2935	62	6510	2953	67	6050	2744	75	4000	1814	75	3800	1724	78	2660	1207	
35	10.67				28	5160	2341	47	5240	2377	56	5280	2395	62	5280	2395	71	3600	1633	71	3380	1533	75	2380	1080	
40	12.19							37	4200	1905	50	4260	1932	58	4300	1950	68	3220	1461	68	3010	1365	72	2150	975	
45	13.72							25	3360	1524	43	3420	1551	52	3460	1569	65	2880	1306	65	2650	1202	69	1940	880	
50	15.24										35	2790	1266	47	2820	1279	61	2580	1170	61	2340	1061	66	1770	803	
55	16.76										24	2290	1039	40	2330	1057	57	2310	1048	57	2060	934	63	1620	735	
60	18.29													33	1930	875	53	2020	916	53	1790	812	60	1490	676	
65	19.81													23	1600	726	49	1690	767	49	1460	662	57	1380	626	
70	21.34																45	1410	640	45	1180	535	54	1280	581	
75	22.86																40	1180	535	40	950	431	51	1190	540	
80	24.38																34	980	445	34	750	340	47	1030	467	
85	25.91																27	810	367	27	570	259	43	850	386	
90	27.43																							39	700	318
95	28.96																							34	560	254
100	30.48																									
105	32.00																									
110	33.53																									
			350 lbs 159 kg			240 lbs 109 kg			190 lbs 86 kg			160 lbs 73 kg			140 lbs 64 kg		Deductions for Stowed Fixed Jib									
			530 lbs 240 kg			350 lbs 159 kg			280 lbs 127 kg			240 lbs 109 kg			200 lbs 91 kg		Deductions for Stowed Telescopic Jib									

Meets ANSI B30.5 Requirements - Do not operate crane or accessories within 10' (3.05 m) of live power lines.
 NOTICE: This chart is for reference only and must not be used for lifting purposes. Consult factory for other boom options.

AREA OF OPERATION

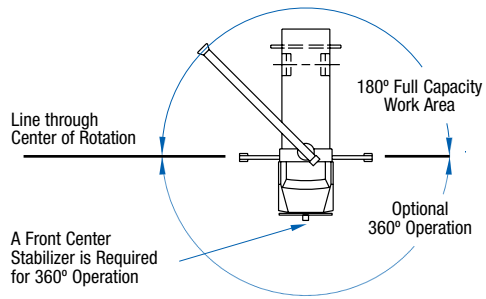

ALLOWABLE LINE PULL

1 Part Line	2 Part Line	3 Part Line	4 Part Line	WARNING
				<p>Anti-two-block system must be in good operating condition before operating crane.</p> <p>Refer to the owner's manual.</p> <p>Keep at least three wraps of load line on the drum at all times.</p>
8,500 lb <i>3 856 kg</i>	17,000 lb <i>7 711 kg</i>	25,500 lb <i>11 567 kg</i>	34,000 lb <i>15 422 kg</i>	.5625" 6 x 25 IWRC (3.5:1 SF) - 29750 lbs breaking strength
7,400 lb <i>3 357 kg</i>	14,800 lb <i>6 713 kg</i>	22,200 lb <i>10 070 kg</i>	29,600 lb <i>13 426 kg</i>	.5625" ROTATION RESISTANT (5.0:1 SF) - 37000 lbs breaking strength

DEDUCTIONS

Load Block	See block manufacturer nameplate
Overhaul Ball	See overhaul ball manufacturer nameplate
Hose Reel	160 lb <i>72,57 kg</i>
Swing Around Jib (Stowed)	See load rating chart

BOOM AND JIB COMBINATIONS

1704

70'

3-Section Boom

23.6' - 40.6' 2-Section Jib



UPTime is the Manitex commitment to complete support of thousands of units working every day.

UPTime

- Includes 24-7-365 parts shipments.
- Utilizes the efficiency of UPNet online parts order system.
- Relies on Manitex's UPTrak support tracking system for performance analysis and resource allocation.
- Features REMan, Manitex's cost effective rebuild/exchange program.
- Provides expert service technicians for troubleshooting and site visits.
- Mandates training; at our facility and yours. It includes coordinated support from all component suppliers.
- Involves every Manitex team member in the support of every Manitex customer.

What does UPTime mean to Manitex customers?

UPTime means reliability.

UPTime means utilization.

UPTime means profitability.

